

# DFC11BR3M fumes and dust extractor with self-cleaning filters and arm

🔧 Sectors [Sanding, Grinding, Welding, Powder blowing,](#)

🔧 Applications: [Mobile](#)

🔧 Issues [Powders, Fumes](#)

COD: DFC11MB00000000



The DFC mobile wheeled fume and dust extractor is designed for the extraction and filtration of even very fine and volatile fumes and micro-dust generated during surface treatment processes of metals or composite materials.



## Detailed description

The DFC mobile wheeled fume and dust extractor is designed for the extraction and filtration of even very fine and volatile fumes and micro-dust generated during surface treatment processes of metals or composite materials:

- Welding
- Grinding
- Deburring
- Sanding
- Rolling
- Cutting

Thanks to its compact size, wheels and handles, it can be easily moved to the vicinity of the work to be done and then suck up the fumes using its rigid hose.

### ADVANTAGES

- Fast suction of fumes and dust near the source due to its high flow rate
- Mobile: allows a variety of welding spots to be reached
- Dust and swarf collection drawer positioned on the pass part of the machine, on request with nylon bag
- Filtration with polyester or antistatic cartridge filter  $\geq 99\%$
- Automatic filter cleaning with compressed air flushing for maximum energy savings and long life of filter elements
- 1100W single-phase power can be connected anywhere with a simple industrial outlet
- Low maintenance due to automatic filter cleaning

### TECHNICAL SPECIFICATIONS

- Sturdy galvanized sheet metal construction;
- 20sqm filter surface with polyester/antistatic polyester cartridges;
- Automatic cleaning by compressed air;
- Built-in 1.1 single-phase fan;
- Handy collection drawer;
- Suction on/off switch;
- Adjustable filter cleaning timer;
- Single-phase electrical plug;
- Handles for easy handling.

### CONSTRUCTION

- Compact and easy-to-handle structure;
- Cartridge filtration with 99% efficiency and re-introduction of air into the room;
- Automatic compressed air filter cleaning with on-board connection and condensate drain
- On-board panel with single-phase plug ready to use;
- Red self-supporting rigid arm of mt 3 diam. 160mm with high capacity fume hood and handle for easy positioning.



## Dimensions

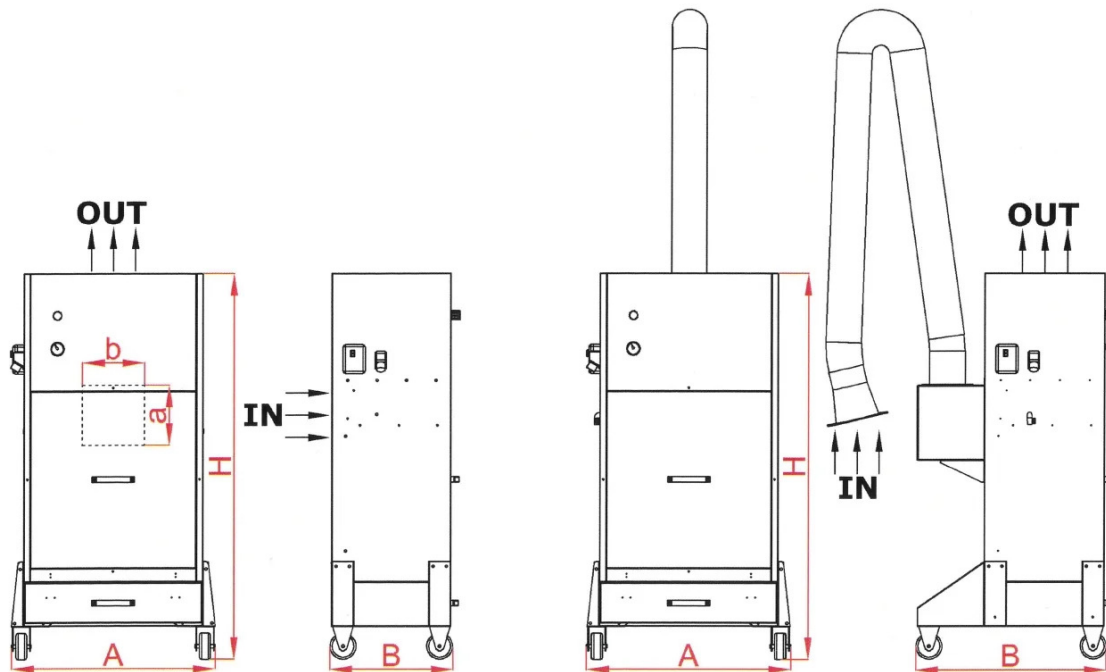

Code	Drawer L	A mm	a mm	B mm	b mm	C mm	D mm	H mm	H1 mm	Ø mm
DFC11MB00000000	70	810	270	540	280	920	870	1750	2650	160

## Technical Data

Code	Nominal flow rate m <sup>3</sup> / h	Noise Db (A)	Max. air temperature ° C
DFC11MB00000000	2000	79	60



## Photogallery



## Accessories



### Hopper and dust collection container kit for DFC11 purifier

TRAMCONTDFC0000

Hopper and dust collection container kit for DFC11 purifier.



## Spare parts



### Replacement cartridge kit for DFC11

Original replacement: no.1 pair of polyester cartridges for DFC11

